

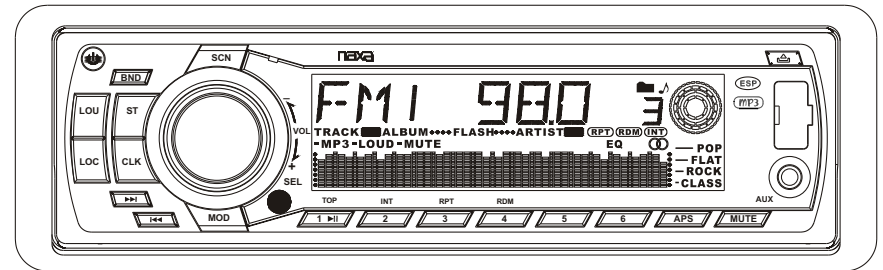

MODEL: NCA-683

INSTRUCTION MANUAL



IMPORTANT INFORMATION REQUIRED BY THE FCC

This device complies with Part 15 of the FCC Rules. Operation is subject to the following two conditions: (1) this device may not cause harmful interference; and (2) this device must accept any interference received, including interference that may cause undesirable operation.

NOTE: This equipment has been tested and found to comply with the limits for a Class B digital device, pursuant to Part 15 of the FCC Rules. These limits are designed to provide reasonable protection against harmful interference in a residential installation.

This equipment generates, uses and can radiate radio frequency energy and, if not installed and used in accordance with the instructions, may cause harmful interference to radio reception, which can be determined by turning the equipment off and on. The user is encouraged to try to correct the interference by one or more of the following measures:

- * Reorient or relocate the receiving antenna.
- * Increase the separation between the equipment and receiver.
- * Connect the equipment into an outlet on a circuit different from that to which the receiver is connected.
- * Consult the dealer or an experienced radio/TV technician for help.

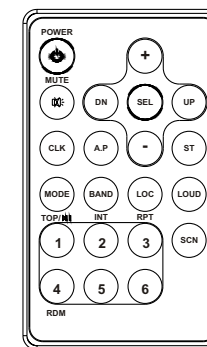

Fold Down Full Detachable PLL Electronic Tuning Stereo AM/FM Radio MP3/CD Player With Text Function, USB Input, SD Card Slot, MP3(ESP) Anti-Skip Protection & Remote Control

Preface

Thank you for purchasing this car audio product.

Please read this manual carefully before operating this car audio product.

Please keep this manual for future use. It will be helpful to you if you are encounter any operational problem.

Selecting fine audio equipment is only the start of your musical enjoyment.

Now it is time to consider how to maximize the enjoyment you will get from knowing how to work your new car stereo receiver.

We hope you enjoy using this product and encourage you to always listen at a moderate, safe sound level to avoid any possible hearing damage or loss.

If you listen to excessively loud sound over time, your hearing can adapt to higher volumes and what sounds "normal" to you may be quite harmful and can cause you to have permanent hearing loss. So please practice "safe sound" and always listen at moderate sound levels only.

Start with your volume control at the lowest setting, and slowly increase the level until you can hear it comfortably and clearly, free from distortion.

Once you have established this comfortable sound level, leave it there.

WARNING!

To reduce the risk of fire or electric shock, do not use the unit in the rain or moisture environment.

To prevent direct exposure to laser beam, do not try open the enclosure.

Visible and invisible laser radiation when open and interlocks defeated.

To protect our environment, do not dispose of electrical equipment in the domestic waste.

Please return any electrical equipment that you will no longer use to the collection points provided for their disposal.

This helps avoid the potential effects of incorrect disposal on the environment and human health. This will contribute to the recycling and other forms of reutilization of electrical and electronic equipment. Information concerning where the equipment can be disposed of can be obtained from your local authority.

SPECIFICATION

GENERAL

Supply Voltage	DC 12 V. Negative Ground
Current Consumption	Max. 15A
Power Output	40W X 4ch (Measured at DC 14.4 V)
Number of channels	2 STEREO channels.
Unit Dimensions	178[W] X 165[D] X 50[H] mm.

FM SECTION

Frequency range	87.50MHz -107.90MHz
Effective sensitivity	3uV.
I.F Frequency	10.7MHz.

AM SECTION

Frequency range	530KHz - 1710KHz
Effective sensitivity	40dB.
I.F Frequency	450KHz

RCA LINE OUT

Output	1000mV @ CD MAX.
--------	------------------

CD PLAYER

System	MP3 Audio System.
Suitable CDs	MP3, WMA, CD,CD-R,CD-RW Disc
Frequency characteristics	20Hz-100Hz ≤ 5dB 10KHz-20KHz ≤ 5dB.
S/N Ratio to CD	50dB [1KHz]

LOCATION AND FUNCTION OF CONTROLS

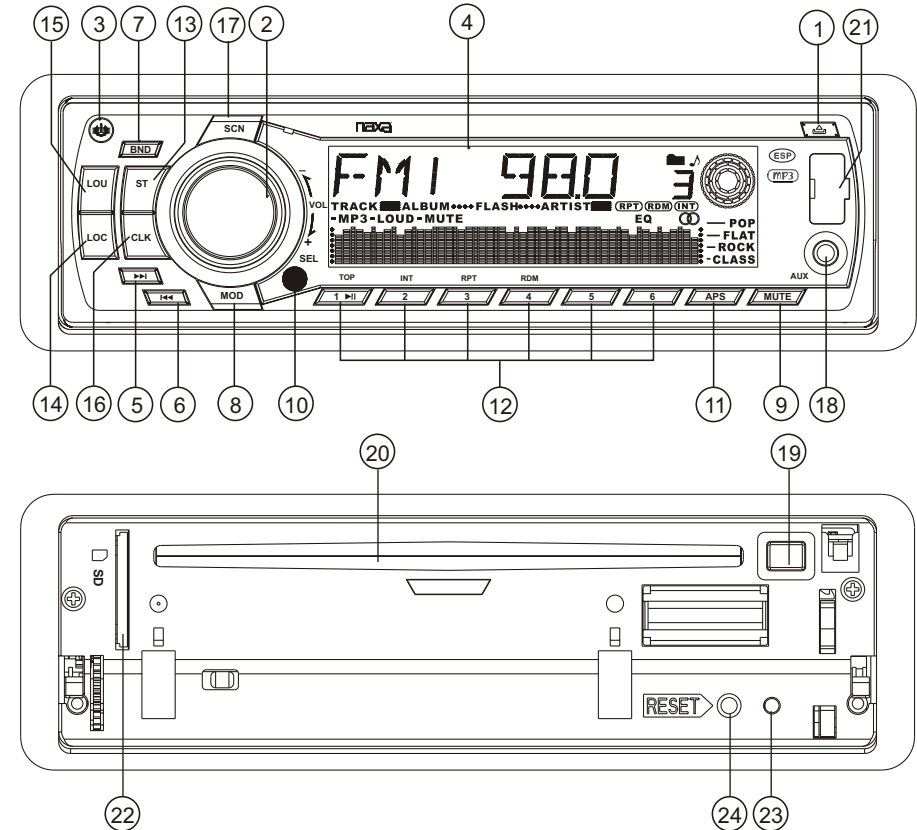

1. OPEN BUTTON

Press the OPEN button to fold down the front control panel. Then a disc can be inserted into the disc slot or ejected by pressing the EJ button. After flipping down the front panel, push it leftwards, then pull the right side of the panel outwards to remove it from the unit chassis.

2. SEL BUTTON (Select) AND VOL KNOB

a) Press the SEL button briefly, it is activated as selecting each mode of E. VOL. -> VOLUME -> BASS -> TREBLE -> BALANCE -> FADER ->

When selecting a desired audio mode, rotate the VOL knob to adjust the audio effect.

In each mode, the waiting time is about 5 seconds, and the time waiting time is over, it returns to the last display mode of tuner or CDP mode.

The control mode of E.VOL is operated with following numeric display.

- VOL: (MIN)00, 01,.....46, 47(MAX).
- BASS/TRE: -07, -06,....,00,....+06,+07
- BAL: 0LR9, 1LR9, ..., 9LR9,...., 9LR1, 9LR0
- FAD: 0FR9,1FR9, ...,9FR9,...., 9FR1, 9FR0

b) When pressed longer 2 seconds, it is activated as cyclical mode of following functions for user's selection.

->BEEP (ON/OFF)-> USER SET(FLAT/CLASSIC/ROCK/POP)

->VOL(LAST/DEFA)->CLK(ON/OFF)->CLK(12/24)mode.

After selecting the desired mode, rotate the VOL knob to select one setup item of the desired mode.

BEEP ON/BEEP OFF

BEEP ON mode: The beep is generated when any key is pressed.

BEEP OFF mode: The beep sound is disabled.

VOL LAST/VOL DEFA

VOL LAST: The radio switches on at the actual volume it had when it was last switched off.

VOL DEFA: After pressing SEL button, AVOL will be displayed. Then you can pre-select a constant switch-on volume by using the VOL knob.

CLK ON/OFF

CLK ON: Clock will always show on the display when power off.

CLK OFF: Clock will disappear on the display when power off.

3. POWER ON/OFF

When the unit is power off, the unit comes to ON by pressing any button on the front panel (except the OPEN key). It also can turn on the unit to insert a disc, SD card or USB stick into their slots or socket. When the unit is power on, press and hold the power button for more than 0.5 seconds, the unit goes into power off mode.

4. LCD Display

5&6. TUNE, SEEK, TRACK, SKIP UP / DOWN BUTTONS

a) During RADIO mode:

Press the >>| or |<< button shortly to manual tune up/down for the desired radio station frequency step by step.

Press and hold the >>| or |<< button for longer 0.5 seconds, to automatically tune up/down for the radio station frequency of strong signal.

b) During disc, SD, USB playback mode:

Press the >>| button briefly to play next track.

Press the |<< button briefly to play the current track from the beginning of it if the playing time is more than 2 seconds.

Press the |<< button briefly to play the previous track if the playing time is less than 2 seconds.

Press the >>| or |<< button and hold to skip forwards or backwards, release to resume normal playback.

TROUBLE SHOOTING

Before using the check list please make all the connections first.

If you still have questions after going through the checklist, please consult your local customer service representative.

Common Symptoms	Cause	Solution
There is no power.	The car ignition is switched off.	If the power supply is properly connected to the car accessory, switch the ignition key to " ON " or " ACC " .
	The fuse has blown.	Replace another fuse according to the wiring diagram.
The CDs cannot be loaded.	Presence of CD disc inside the player	Remove the disc in the player then put a new upward
The CDs are loaded only halfway into the CD tray.	The transport screws have not been removed.	Remove the transport screws before using.
The device does not work correctly (EJECT, LOAD, PLAY)	Inserting the disc in upside down	Insert the compact disc with the label facing upward
	The surface of CD is extremely dirty or it is damaged.	Clean the CD or try another CD, if this works correctly, the first CD is properly damaged.
	Temperature inside the car is too high.	Cool off until the ambient temperature returns to normal
There is no sound.	The volume control is set too low.	Turn up the volume properly.
	The device has not been correctly connected.	Check the power and earth connection according to the wiring diagram.
The operation keys do not work	1.The built-in microcomputer is not operating properly due to noise 2.Front panel is not properly fix into its place	1. Switch the device off and on again. Or press the RESET button to resume the program. 2. Reinstall the front panel
The sound of the CD player skips	The installation angle is more than 30 degrees	Adjust the installation angle to less than 30 degrees
	The surface of the road is uneven.	Wait until the road becomes smoother before playing the CD.
	The surface of CD is extremely dirty or it is damaged.	Clean the CD or try another CD, if this works correctly, the first CD is properly damaged.
No radio reception.	The antenna cable is not connected.	Insert the antenna cable firmly into the antenna socket of the device.
In automatic search mode the radio does not stop at a transmitting station.	The transmission signals are too weak.	Tune in to a radio station manually.

CARE FOR USING CD'S:

About CD-R/CD-R/W discs:

In addition to commercially-recorded audio CD's, this unit can play CD-R and CD-R/W discs. In some cases, particularly when recorded on older CD burners, some CD-R and CD-R/W discs may not play. Also, whenever you are recording a CD for playback in this receiver, it is recommended that you record at 24x or slower speed for CD-R and 4x or slower for CD-R/W to achieve higher signal quality and better playback performance.

1. To keep the disc clean:
Do not attach any sticker or adhesive tape on the disc.
Handle the disc by its edge to keep the disc clean and do not touch the surface.
Before playing a disc, wipe it off with a clean, dust-free cleaning cloth.
Wipe the disc outwards from the disc center.
2. When one has already been inserted. Doing so may damage the unit. Insert a disc with labeled surface up, or it will damage the unit.
3. Do not expose the disc to direct sunlight or nearby heat sources such as heating vents, caliduct which can cause the disc to warp.
Do not leave disc in a car if it is parked in direct sunlight as that will lead to a considerable rise in the temperature inside the car.
4. Do not use any secondhand or rented disc, usually, there is glue on the surface of those discs, it will stop the unit working and damage it.
5. Always store the disc in its case for protection. Scratched up discs will produce poor sound performance and cause CD player to skip.
6. In raining day or wet area, the moisture may form on the disc or the optical parts, the playback may not be possible. If moisture forms on the disc, wipe it off with a soft cloth.
If moisture forms on the optical parts of the unit, allow the unit to sit for about one hour with power on.
7. Do not use solvents such as benzine or thinners. Commercially available cleaners or anti-static spray will damage the unit.

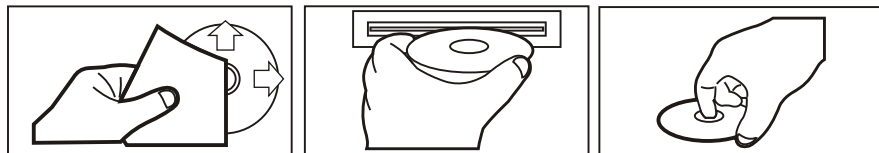

7. BAND BUTTON

During radio mode, press the BND button briefly to select the radiobroadcasting band you would like to hear. The AM/FM band is toggled cyclically through the tuning bands: ->FM 1-> FM 2 -> FM 3 -> AM 1->AM 2 ->.

8. MODE BUTTON

Press the MODE button to change among tuner (radio), disc (when a disc is loaded), SD card (when an SD card is inserted), USB (when an USB stick is inserted) and AUX mode.

9. MUTE BUTTON

This button serves to switch the MUTED state on/off.

Press the MUTE button to suppress the loudspeaker temporarily, and press again to resume listening. The muted state will be also released when the MODE, SEL button is pressed and VOL knob on the front panel is used.

10. INFRARED REMOTE CONTROL SENSOR

11. A.P BUTTON (Auto-storage /Preset scan)

During radio mode:

- 1) when long pressing for more than 1 seconds, the radio searches from the current frequency and checks the signal strength level until 6 stations are found. And then the 6 stations frequency are preset to the corresponding preset memory numbered bank. The auto-storage operation is implemented in the each selected band. When the auto-storage operation is finished, the radio execute the Preset Scan.
- 2) when short pressing, the radio searches for each preset station in the current band and holds at that preset number for 5 seconds with releasing mute, and then search again.

During MP3/WMA file in disc, SD or USB mode, press the A.P button short, it is activated selecting song mode, and the TRK 000 (if the number of tracks is less than 100 and more than 9, it will be TRK 00) will be visible on the LCD display and the hundreds digit 0 that the MP3/WMA disc, SD card or USB contains will flash.

Rotate the VOL knob to select and enter the number on the flashing digit place from 0 to 9.

Then press the A.P button to confirm the entered number and the 0 on the tens digit will be flashing.

Rotate the VOL knob to select and enter the number on the flashing digit from 0 to 9.

Then press the A.P button to confirm the entered number and the 0 on the units place digit will be flashing.

Rotate the VOL knob to select and enter the number on the flashing digit from 0 to 9.

After finishing enter all the number of the song serial number on the flashing digit, press the SEL button to play the corresponding track.

12. PRESET STATION MEMORY AND TOP/>||, INT, RPT, RDM BUTTONS

a) During radio mode:

Go to any preset station by pressing one of the 6 preset station buttons (1-6). If one of these buttons is pressed for more than 2 seconds, the station currently being listened to will be memorized into the selected preset button.

b) During disc, SD or USB mode:

- 1) Press the TOP/>|| button briefly to interrupt the playback of the disc, SD or USB. Press again to resume normal playback of the disc, SD or USB. Press the TOP/>|| button and hold for approximately 0.5 seconds to play the first track of the disc, SD or USB.
 - 2) Press the INT button to sample the first 10 seconds part of each track, and the INT ON will be visible on the LCD display. In the process of INT, press INT button again to stop sampling and to continue playing the current track, and the LCD will display INT OFF.
 - 3) Press the RPT button once to play the current track repeatedly, and the RPT ONE will be visible on the LCD display. During MP3/WMA disc, SD or USB mode, press the RPT button twice continuously to play the current folder repeatedly, and the RPT ABM will be visible on the LCD display. In the process of RPT, press RPT button again to stop playing repeatedly mode and the LCD will display RPT OFF.
 - 4) Press the RDM button to play all tracks on disc in random order, and the RDM ON will be visible on the LCD display. In the process of RDM, press RDM button again to stop playing in random order and the LCD will display RDM OFF.
- c) During the normal playback of MP3/WMA disc, SD, USB:
Press the radio preset button 6 and 5 to move up and down 10 tracks at a time.

13. ST/MO BUTTON

In FM mode, press the ST briefly to select stereo or mono sound mode.

14. LOC/DX BUTTON

Radio station search mode is divided by this LOC/DX switch, this button can be used to control an attenuator in the tuner during search.

In radio mode, press the LOC button to change local reception or distance reception. Local mode improves reception in some areas where the signal is too strong.

Note: This button is only for FM reception. In AM mode, LOC is void.

15. LOUDNESS BUTTON

When press shortly, the LOUD mode is turned on, its to enhance the bass sound effect when the volume level is low. Press again to cancel the loudness effect.

16. CLOCK BUTTON

Press the CLK button briefly to display time for 5 seconds on the display, and then returns to its previous display unless the button is pressed again. Then press the CLK button and hold for more than 1 seconds until the real time flashes on the display. Then you can adjust HOUR or MINUTE by rotating the VOL knob.

INSTALLATION

INSTALLATION METHOD

This is an anti-theft installation method.

The main unit wears a METAL MOUNTING SLEEVE.

Please connect the wiring, eg, the Power Supply, the Speakers and the Antenna according to the requirements of this Instruction Manual, then install the metal mounting sleeve into the car as per the diagram illustrated below.

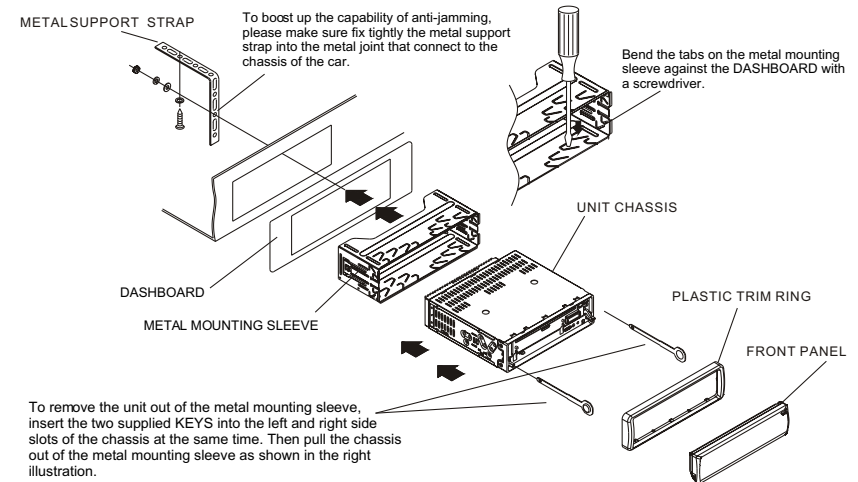

NOTE

Before mounting and operating the CD player, remove the metal mounting sleeve illustrated by the arrows.

Remove the two screws that fix the CD deck mechanism player during transportation before mounting the player.

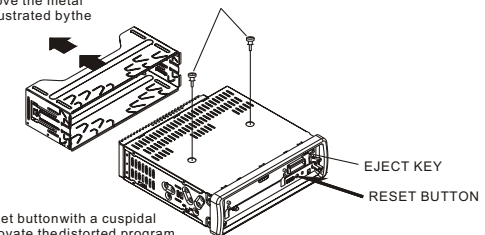

WIRES CONNECTION

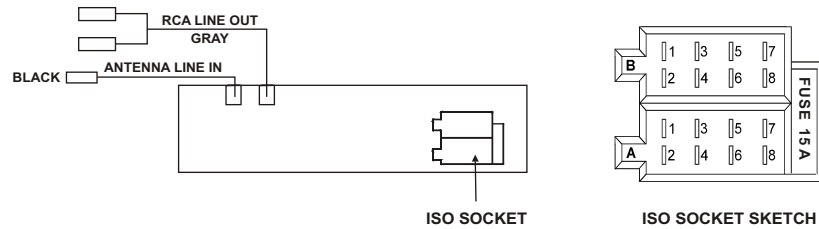

CONNECTOR A

- 1.
- 2.
- 3.
4. Memory +12V
5. Auto Antenna Output
- 6.
7. 12V (To Ignition Key)
8. GROUND

CONNECTOR B

1. Rear Right Speaker (+)
2. Rear Right Speaker (-)
3. Front Right Speaker (+)
4. Front Right Speaker (-)
5. Front Left Speaker (+)
6. Front Left Speaker (-)
7. Rear Left Speaker (+)
8. Rear Left Speaker (-)

17. SCAN BUTTON

Press the SCN button to scan the radio frequency. If a valid signal has detected, the current frequency will be hold and blinking for 5 seconds, then press SCN again to stop scan and remain the current frequency; otherwise, the radio will go on to scan the other radio frequency 5 seconds later.

18. AUX INPUT JACK

Press the mode button to select auxiliary input playing mode. Then you can connect any matched external audio device to this socket. Use the volume knob to adjust volume.

19. EJECT KEY

In the power on state, the loaded disc can be ejected by pressing the EJ key.

20. CD SLOT

21. USB SOCKET

When needing to play the file in the USB stick, turn over the plastic cover cap then insert the USB stick into the USB socket. The system will change into the USB mode automatically, and then play the first file in the USB. When no needing to do USB operation, please cover the plastic cover cap.

22. SD CARDSLOT

When you need to play the file in the SD card, insert the SD card into the card slot. The system will change into the mode automatically, and then play the first file in the SD.

Note:

When SD card and USB stick are both inserted into their slot or socket, the system will change into the USB mode automatically.

23. FLASHING LED

When the front control panel is removed this indicator flashes.

24. RESET BUTTON

Before operating the unit for the first time, or after replacing the car battery or changing the connections. You must reset the unit. Press this button with a cuspidal object. This operation will erase the clock setting and some stored contents.

OPERATION OF REMOTE CONTROL

1. Power On/Off
2. Mute Button
3. Loudness Button
4. Level/MENU UP Button
5. SEL/MENU Button
6. Level/MENU Down Button
7. MO/ST Button
8. A.P Button
9. Band Button
10. Mode Button
11. Tune/Seek Up And Track Skip Up/FF Button
12. Tune/Seek Down And Track Skip Down/REW Button
13. SCAN BUTTON
14. Clock Display/Setting Button
15. LOC/DX Button
16. CD Track TOP/>||/Radio Preset 1
17. CD Track INT/Radio Preset 2
18. CD Track RPT/Radio Preset 3
19. CD Track RDM/Radio Preset 4
20. Radio Preset 5
21. Radio Preset 6

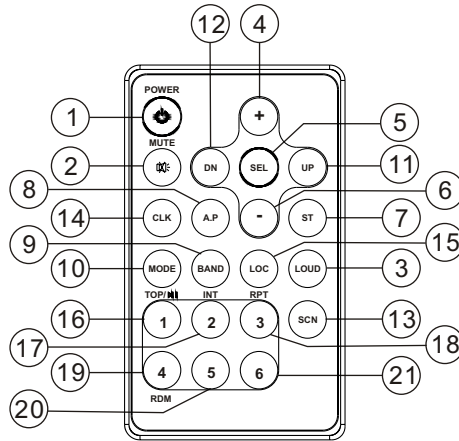

MAINTENANCE OF REMOTE CONTROL

An insulation tag was installed in your remote by the manufacturer to prevent the battery from draining. Removing the tag from the remote before using.

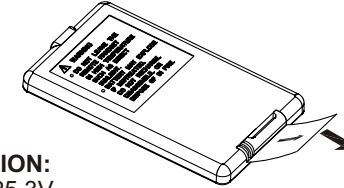

BATTERY INFORMATION:

Lithium Battery: CR2025 3V

Battery Life: Approximately 6 months.

Replacing the Battery from the Remote Controller:

- 1) Remove the battery holder by pressing the locking tab with your thumb and pulling it out.
- 2) Replace the battery with the same type and the "+" side facing up.
- 3) Gently push in the holder until securely locked into place.

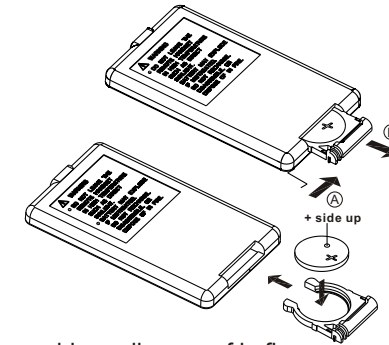

! WARNING:

- Do not recharge, disassemble or dispose of in fire.
- Battery leakage may cause damage to the unit.
- To avoid the risk of accident, keep batteries out of reach of children.